

Birth and Growing Pains of the Internet

Prof. C. Dianne Martin

CSci 41

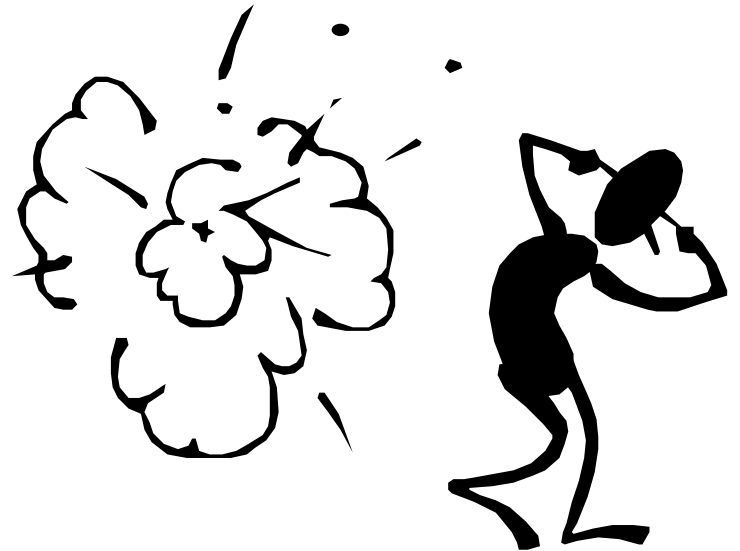

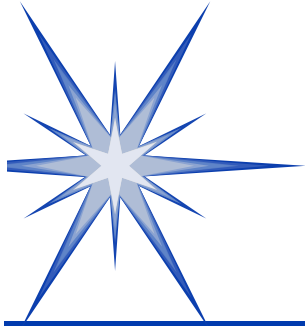

First Idea: Hypertext

- **Vannevar Bush: How We May Think, Atlantic Monthly, 1945**
 - **Proposed Memex to make and follow memory extensions for information**
- **Doug Engelbart, 1960's, proposed NLS (oNLSERVICE) and invented the mouse to do hypertext browsing, editing, email**
- **Ted Nelson, 1965, hypertext**

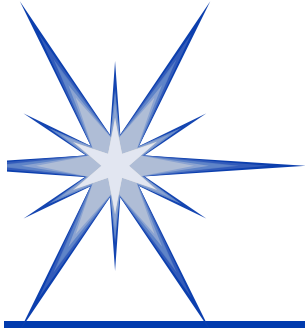

Second Idea: Networks

- **Internet: a distributed, interoperable network of multiple format data interconnections, including WWW**
 - **1969 ARPANET project - DoD**
 - **Reliable digital communications network that could withstand nuclear attack due to redundant paths**
 - **Originally only “hard core” computer scientists and government research labs**
 - **1975-85 BitNet - universities established a network supported by cooperating members who provided nodes to support email.**

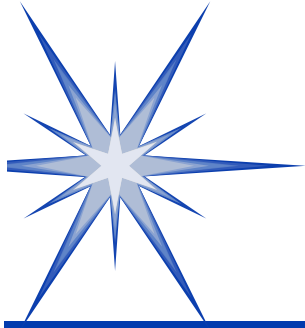

How the Internet Evolved

➤ **Origins of the Internet**

- **July 1961 = Leonard Kleinrock at MIT published 1st paper on packet switching**
- **August 1962 = J.C.R. Licklider of MIT in discussing his "Galactic Network"**
- **1967 = plan for the "ARPANET"**

➤ **The Initial Internet**

- **The original ARPANET grew into the Internet. Internet was based on the idea that there would be multiple independent networks of rather arbitrary design, beginning with the ARPANET as the pioneering packet switching network, but soon to include packet satellite networks, ground-based packet radio networks and other networks.**

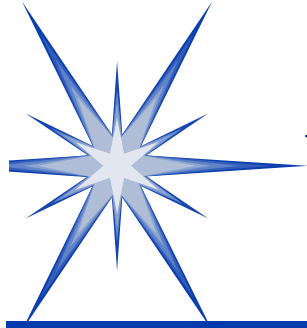

Who “Invented” the Internet?

- **1973: Bob Metcalfe’s PhD dissertation at Harvard describes the Ethernet protocol**
- **1973: Bob Kahn poses the Internet problem, starts ARPA research**
- **1973: Vint Cerf sketches basic gateway architecture on back of an envelope in hotel lobby**
- **1974: Cerf and Kahn publish paper on protocol for a packet network**
- **1994: Al Gore?**

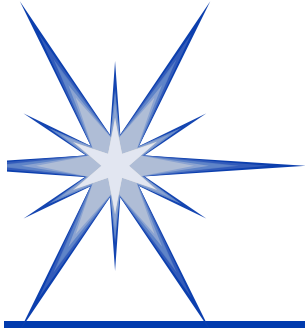

How the Internet Evolved (continued)

- **1970's UseNet - free nets, non-profits**
- **1980's ARPANET divided into ARPANET and Milnet**
 - **NSF provided NSFNET to link them - Internet**
 - **1983 500 computers were connected to Internet**
- **1990's - NSF-funded backbone, non-commercial**
- **1990's commercial ISP's-CompuServe, MCI**
- **1990's Tim Berners-Lee: WWW (Memex!)**
- **Since 1995 - astronomical growth, commercialization**
- **Tangle of information - browsers, search engines, etc.**

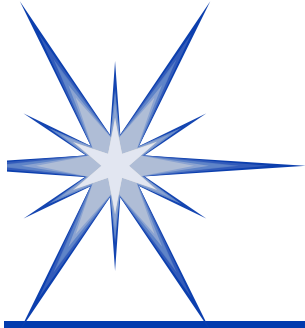

Concepts - Proving the Ideas

- **New Protocol = Transfer Control Protocol/Internet Protocol (TCP/IP). While NCP tended to act like a device driver, the new protocol would be more like a communications protocol**
- **Four ground rules were critical to early thinking:**
 1. **Each distinct network would have to stand on its own and be interoperable**
 2. **Communications would be on a best effort basis. If a packet didn't make it to the final destination, it would shortly be retransmitted from the source.**
 3. **Black boxes would be used to connect the networks; these would later be called gateways and routers.**
 4. **There would be no global control at the operations level.**

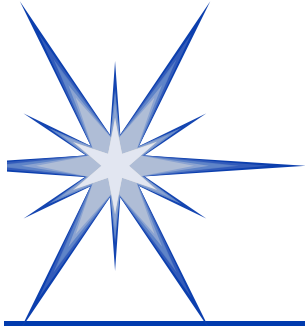

Transition to Widespread Infrastructure - \$\$ Issue

- Validated by select group of CS professors, new protocols being developed
- The usefulness of computer networking - especially electronic mail - by the mid-1970s computer networks had begun to spring up wherever funding could be found for the purpose.
 - The U.S. Department of Energy (DoE) established MFENet for its researchers in Magnetic Fusion Energy
 - DoE's High Energy Physicists responded by building HEPNet.
 - NASA Space Physicists followed with
 - CSNET established for the (academic and industrial) Computer Science community with an initial grant from the U.S. National Science Foundation (NSF).
 - AT&T's dissemination of the UNIX spawned USENET,
 - BITNET linked academic mainframe computers in an "email as card images" paradigm.
- British JANET (1984) and U.S. NSFNET (1985)

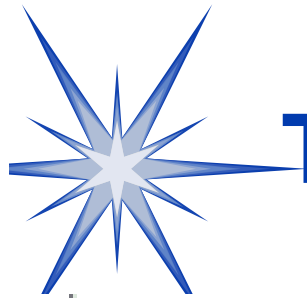

Timeline of Internet Development

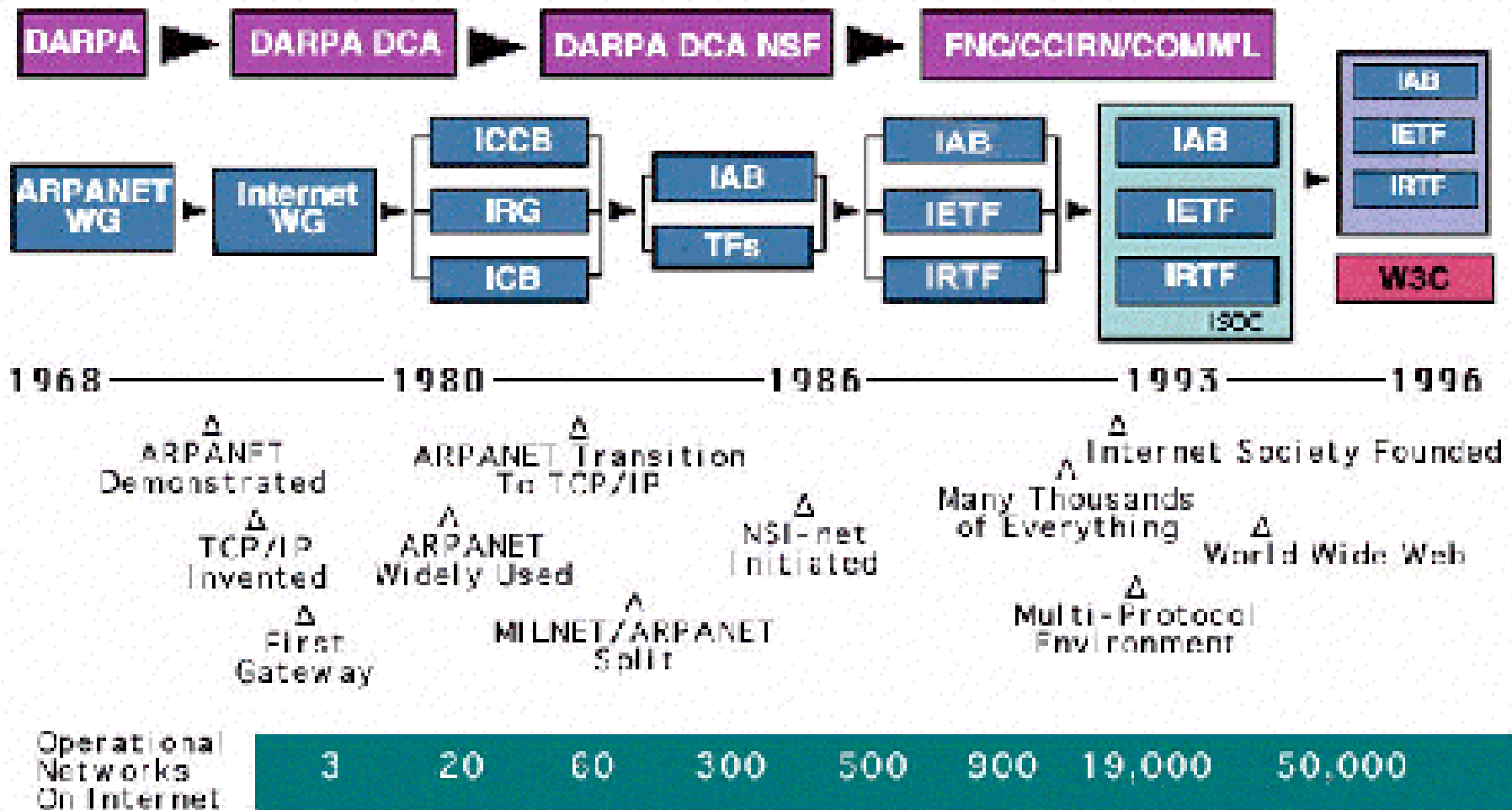

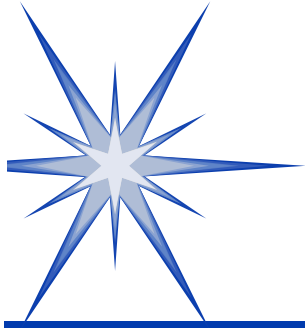

Netiquette on the Internet

- **Be careful what you send in email**
- **DON'T SHOUT!**
- **Don't flame!**
- **Be careful with Reply All**
- **Question: What was the worst e-mail experience you ever had?**

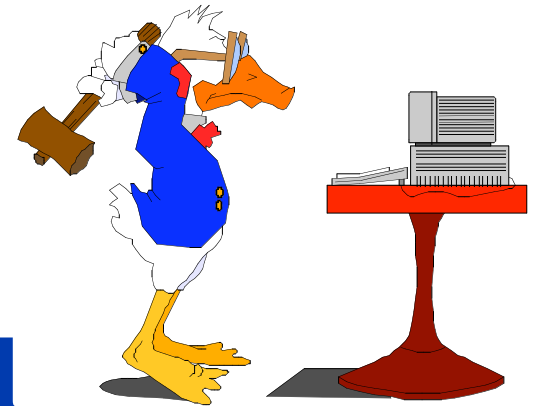

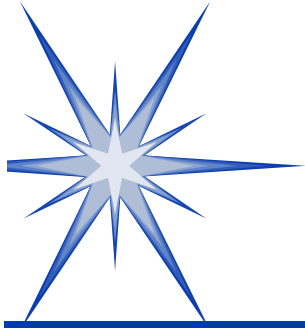

Brief History of WWW

- **1945 Vannevar Bush “memex” [hypertext]**
- **1960s Doug Engelbart prototypes "oNLine System" (NLS)**
- **1980 Tim Berners-Lee writes a notebook program, "Enquire-Within-Upon-Everything"**
- **1990 TBL implemented a line mode browser and WorldWideWeb browser/editor [hypermedia]**
- **1993 NCSA release first alpha version of Marc Andreessen's "Mosaic for X" graphical browser**
- **1994 first WWW International Conference, formation of W3C**

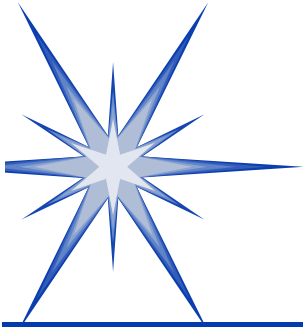

Web Architecture

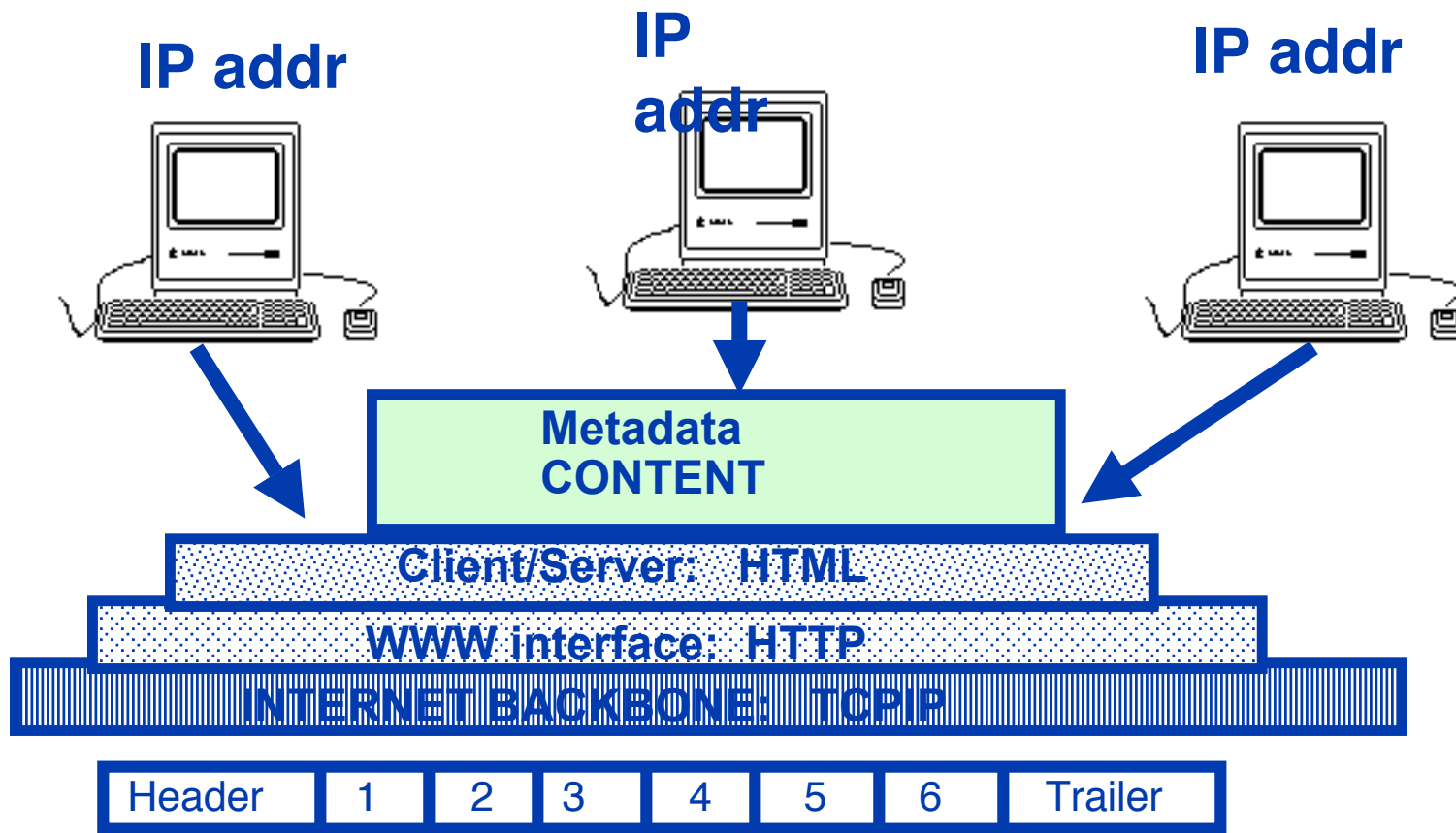

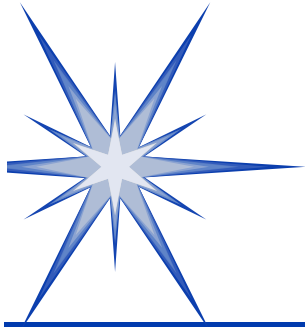

Explosion of the WWW

Unsafe at any speed??

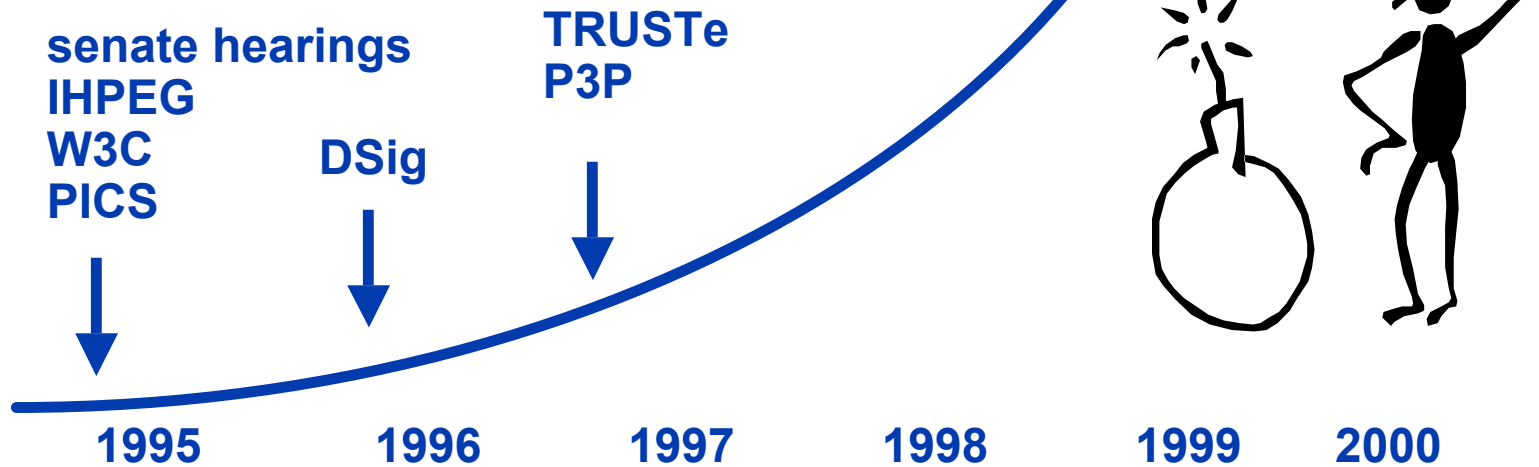

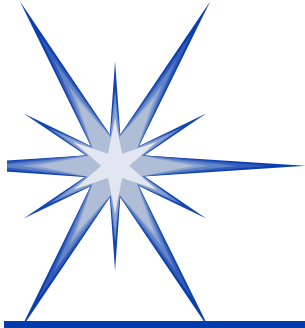

W3C Founding Principles

- **Technology can be used to provide safe internet access**
- **Technology can be used to protect users from unreliable, unwanted, offensive or illegal information as well as from hackers, viruses, unwanted intrusion, invasion of privacy, and electronic fraud.**
- **W3C sets up working groups to establish technical standards and data exchange protocols to be used by others to develop systems to accomplish the above.**

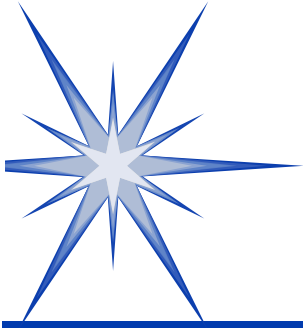

12 Networking Truths

(1) It Has To Work.

(2) No matter how hard you push and no matter what the priority, you can't increase the speed of light.

(2a) (corollary). No matter how hard you try, you can't make a baby in much less than 9 months.

(3) With sufficient thrust, pigs fly just fine. However, this is not necessarily a good idea. It is hard to be sure where they are going to land, and it could be dangerous sitting under them as they fly overhead.

(4) Some things in life can never be fully appreciated nor understood unless experienced firsthand. Some things in networking can never be fully understood by someone who neither builds commercial networking equipment nor runs an operational network.

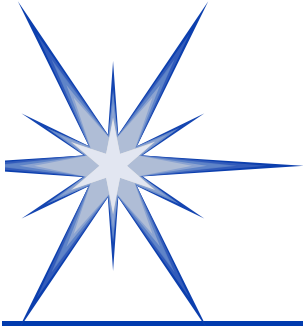

12 Truths (continued)

(5) It is always possible to agglutinate multiple separate problems into a single complex interdependent solution. In most cases this is a bad idea.

(6) It is easier to move a problem around (for example, by moving the problem to a different part of the overall network architecture) than it is to solve it.

(6a) (corollary). It is always possible to add another level of indirection.

(7) It is always something

(7a) (corollary). Good, Fast, Cheap: Pick any two (you can't have all three).

(8) It is more complicated than you think.

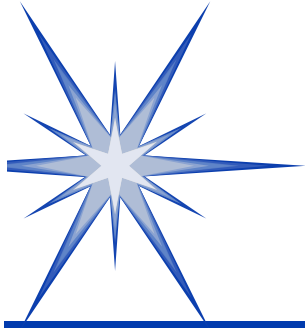

12 Truths (continued)

(9) For all resources, whatever it is, you need more.

(9a) (corollary) Every networking problem always takes longer to solve than it seems like it should.

(10) One size never fits all.

(11) Every old idea will be proposed again with a different name and a different presentation, regardless of whether it works.

(11a) (corollary). See rule 6a.

(12) In protocol design, perfection has been reached not when there is nothing left to add, but when there is nothing left to take away.

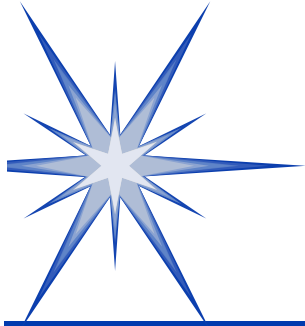

Credits for 12 Truths

References: The references have been deleted in order to protect the guilty and avoid enriching the lawyers.

Author's Address

Ross Callon

Internet Order of Old Farts

c/o Bay Networks

3 Federal Street

Billerica, MA 01821

Phone: 508-436-3936

EMail: rcallon@baynetworks.com

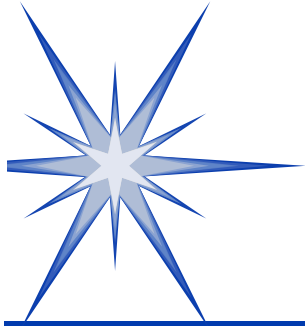

Growth of Internet Hosts

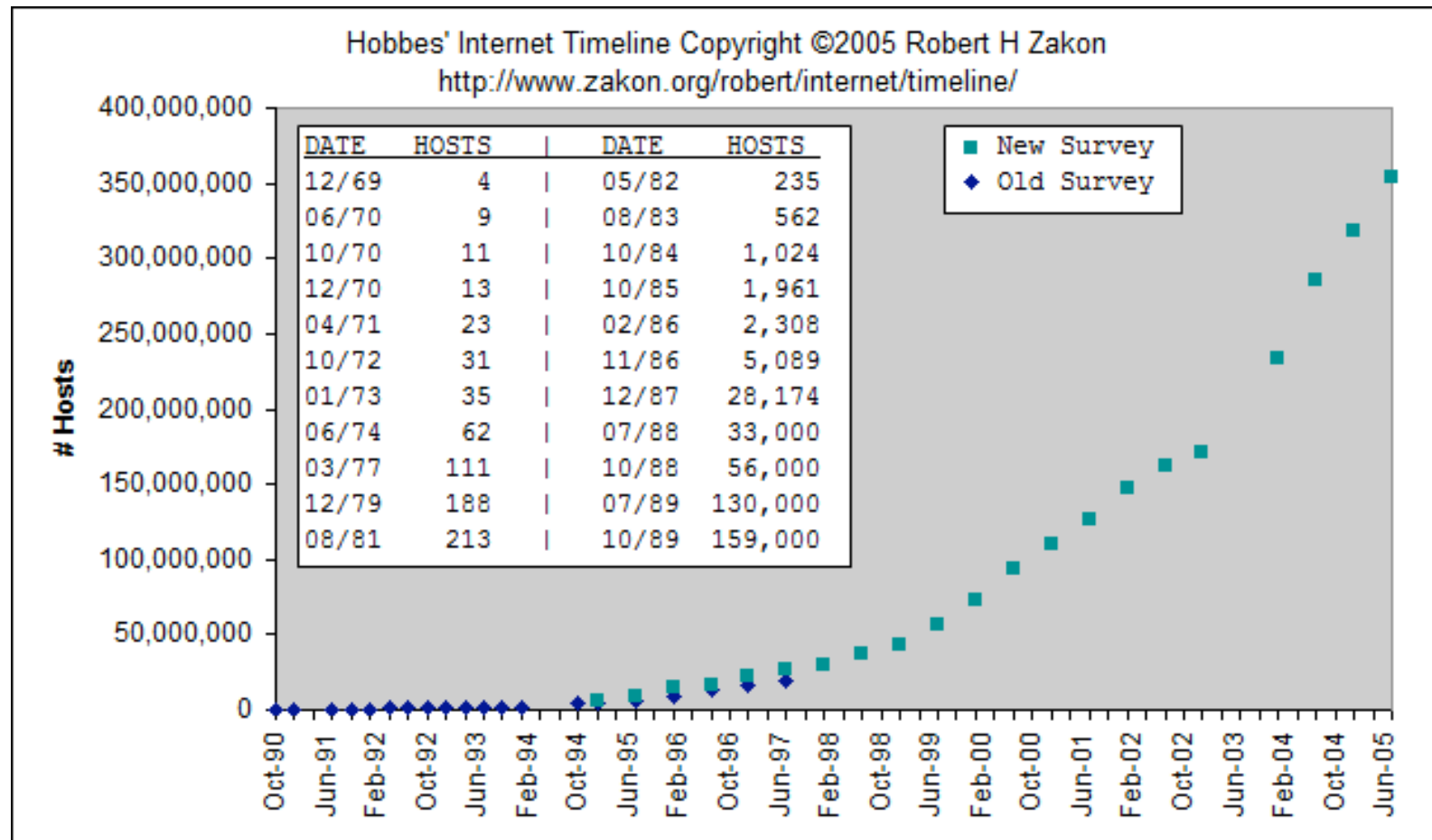

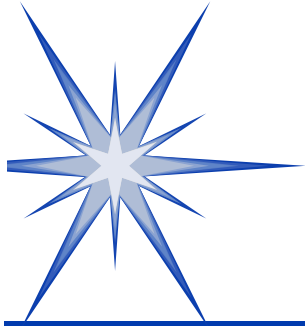

Growth of Domains

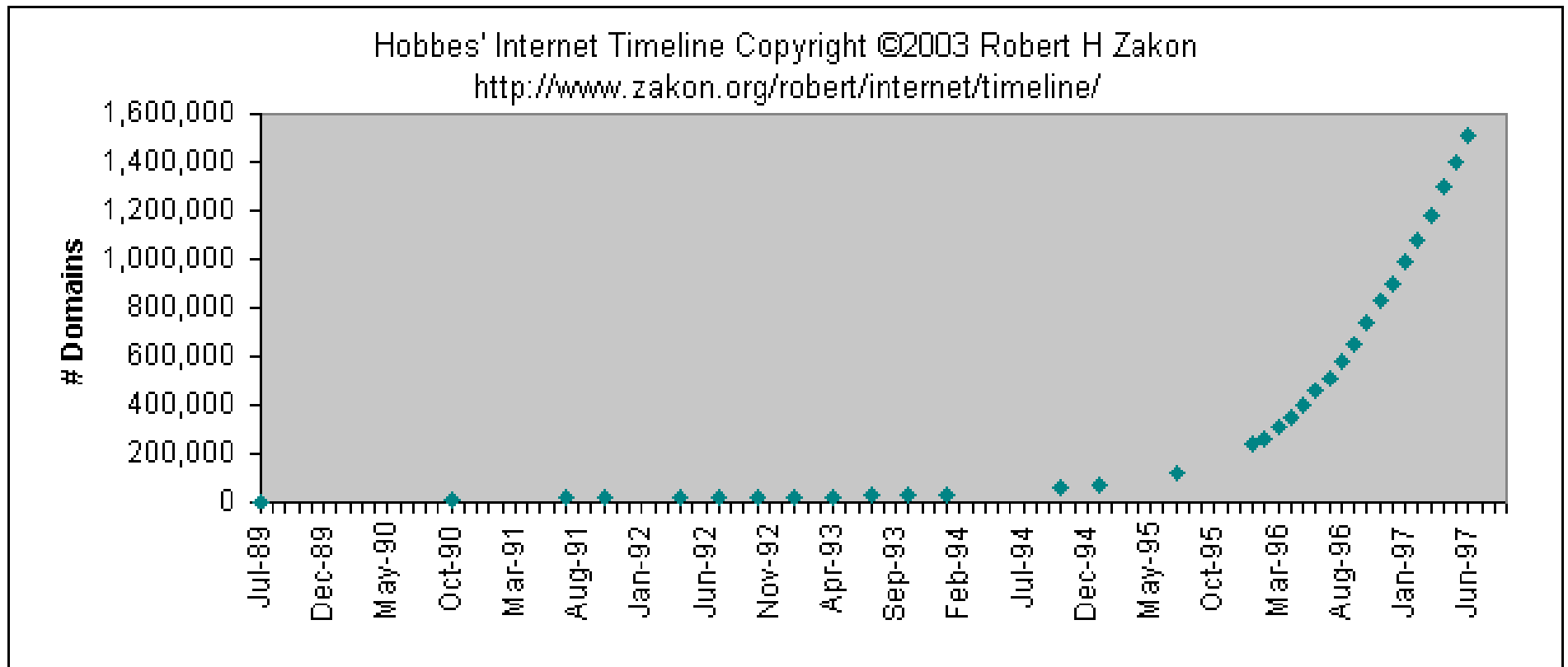

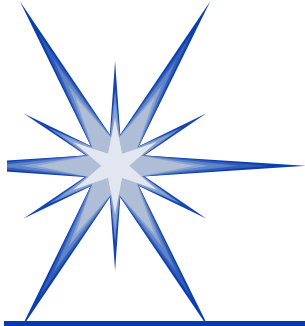

Growth of # of Networks

Hobbes' Internet Timeline Copyright ©2003 Robert H Zakon
<http://www.zakon.org/robert/internet/timeline/>

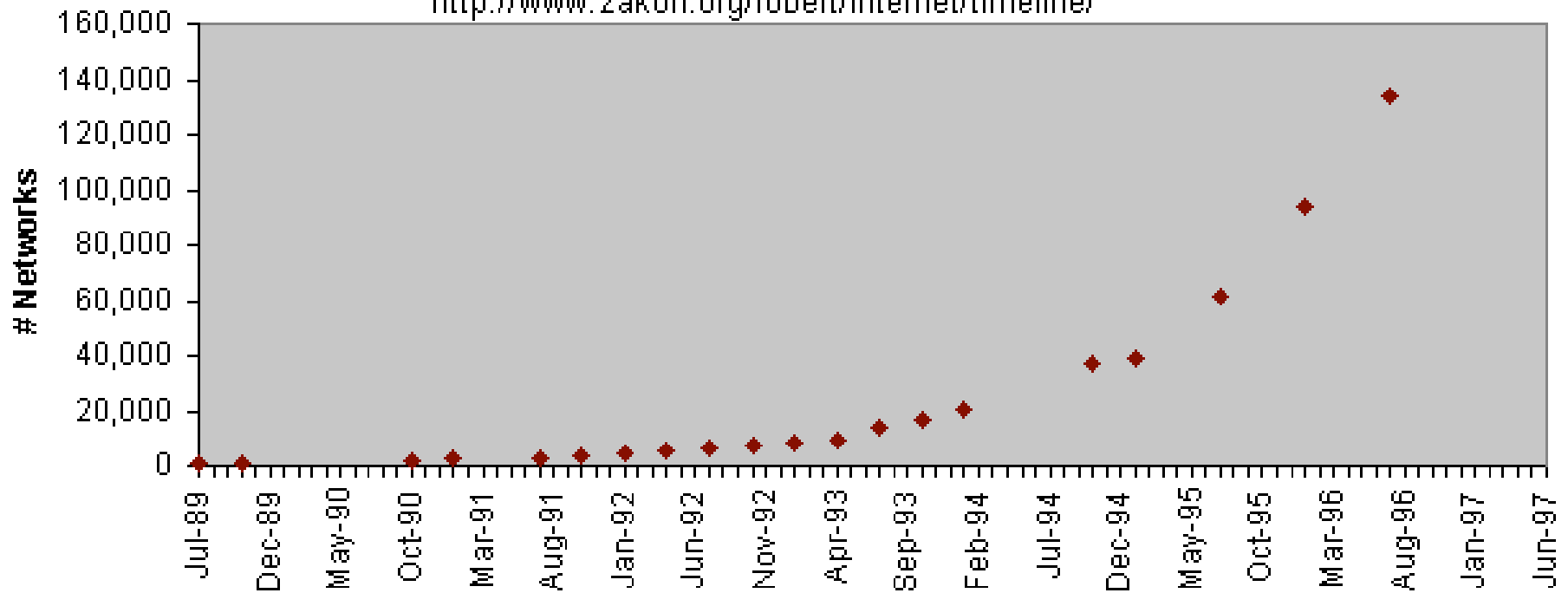

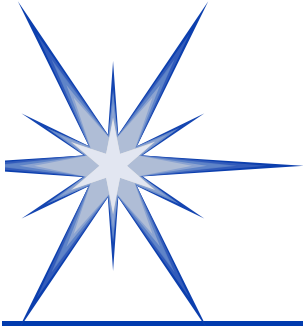

Growth of the WWW

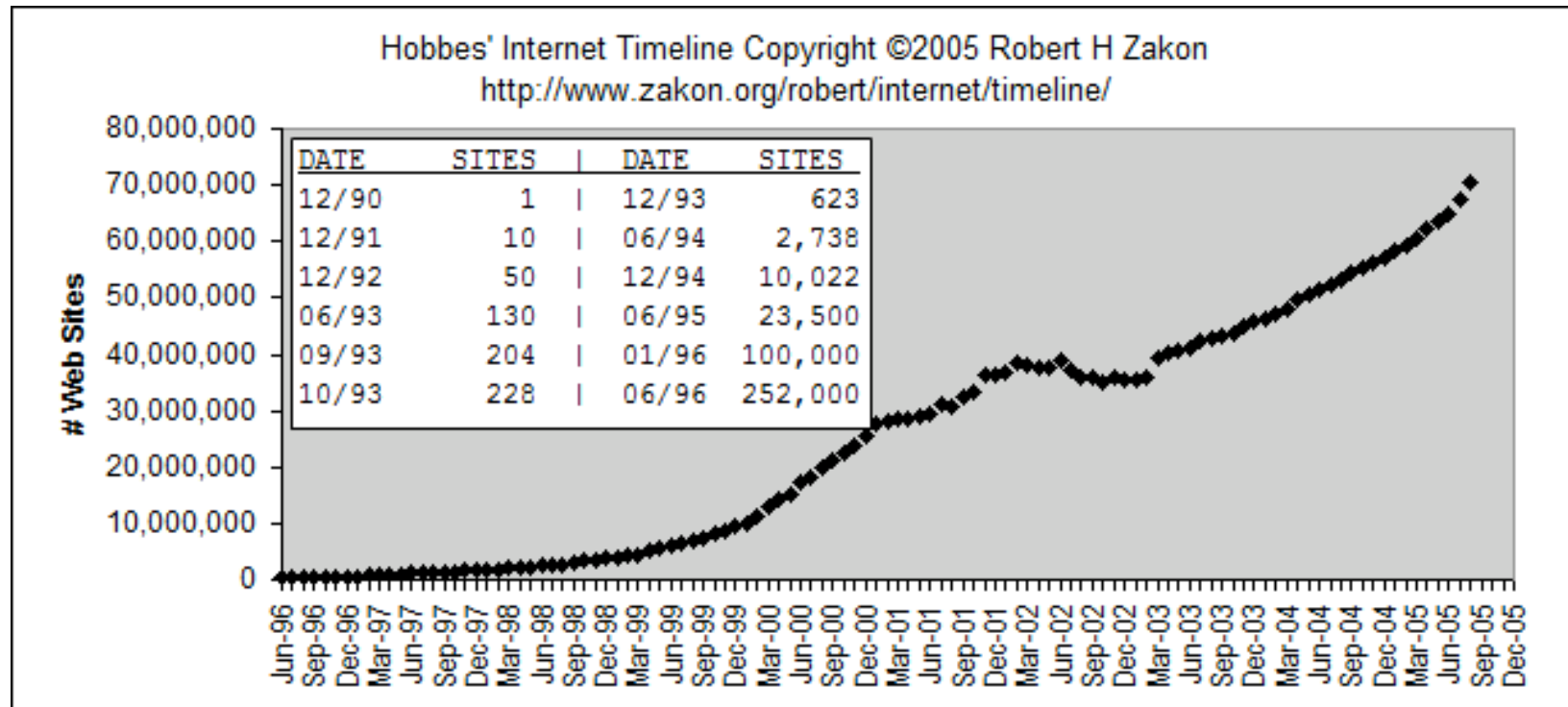

<http://www.zakon.org/robert/internet/timeline/>