

## CS 135 Fall 2010: Homework 2. Due September 21, 10am

Submit using blackboard.

1. Do question 3.6 from the Textbook.
2. Design a circuit with three inputs ( $x, y$  and  $z$ ) representing the bits in a binary number, and three outputs ( $a, b$  and  $c$ ) also representing bits in a binary number. When the input is decimal 1, 2 or 3, expressed in binary, the output should be one less than the input. When the input is 4, 5, or 6, the output should be one more than the input. If the input is 0 (binary 000) then output is 7 (binary 111), and if the input is 7 (binary 111) then output is 0 (binary 000). For example, if the input is 011 (representing decimal number 3) then the output should be 010 (representing  $3-1=2$ ). If the input is 101 (representing decimal number 5) then out should be 110 (represents decimal  $5+1 = 6$ ). Show your truth table, the Boolean function for the above circuit, and the final circuit (using only OR gates, AND gates, and NOT gates).
3. The NAND gate is logically complete (i.e., any logic function can be built using only NAND gates). Use only NAND gates to construct a circuit that computes the XOR (exclusive-OR) function (i.e., circuit takes two inputs  $A, B$  and output is  $A \text{ XOR } B$ ).
4. A very small company has hired you to install a security system. The brand of system that you install is priced by the number of bits encoded on the proximity cards that allow access to certain locations in a facility. Of course, this small company wants to use the fewest bits possible (spending the least amount of money as possible) yet have all of their security needs met. The first thing that you need to do is to determine how many bits each card requires. Next, you have to program card readers in each secured location so that they respond appropriately to a scanned card. This company has four types of employees and five areas that they wish to restrict to certain employees. The employees and their restrictions are as follows:
  - a. The Big Boss needs access to the executive lounge and the executive washroom.
  - b. The Big Boss's secretary needs access to the supply closet, employee lounge, and executive lounge.
  - c. Computer room employees need access to the server room and the employee lounge.
  - d. The janitor needs access to all areas in the workplace.Determine how each class of employee will be encoded on the cards and construct logic diagrams for the card readers in each of the five restricted areas.
5. Find the truth table that describes the following circuit. Find the Boolean function being implemented.

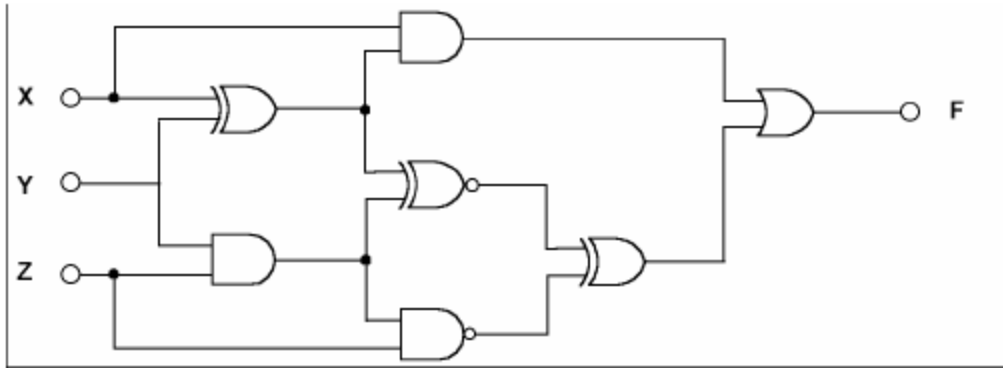

6. Create the Karnaugh maps and then simplify for the following functions. After simplification, provide the gate level circuits to implement the functions:

a.  $F_1(x,y,z) = x'y'z' + x'yz + x'yz'$

b.  $F_2(x,y,z) = x'yz + x'yz' + xz$

c.  $F_3(w,x,y,z) = w'x'y'z' + w'x'y'z + w'x'yz' + w'xyz' + wx'y'z' + wx'y'z + wx'yz'$

7. For the circuit in question 5 (of this homework), you have found the Boolean function being implemented. Is there a simpler implementation – specifically, is there a 2-level circuit using fewer gates? You must provide your solution to justify your answer – a yes or no answer earns you no points.